

ANTHONY
LIFTGATES, INC.®

AST



*Shown with optional features.

TUCKUNDER™ SERIES

LIFTING CAPACITIES (LBS):
1500, 2000, 2500, 3000



KEY ADVANTAGES

- 1. HD Mechanical Safety Latch**
Redundant-system stowage in addition to hydraulic lock.
- 2. Spring Assist Platform**
Dual torsion springs provide effortless platform operation.
- 3. EZ Mount**
Ships factory assembled, filled, and tested with notched center mark for easy installation. Floor extension may be bolted to the truck.
- 4. CHS - Centralized Hydraulic System**
All sensitive hydraulic and electrical components housed safely within the stainless steel pump box.
- 5. Lifetime-Warranty Service Free Bushings**
Used at all critical pivot points to reduce wear without the need for routine lubrication.

QUALITY, RELIABILITY, CUSTOMER SERVICE

MADE IN THE USA 

STANDARD FEATURES

- **Circuit Protection**
200 Amp fuse protects truck wiring from a "dead short".
- **Marine Duty Potted Toggle Switch**
Heavy duty toggle, potted to permanently separate and seal electrical connections from corrosion.
- **3/16" Steel Floor Extension**
Rugged and attractive surface.
- **Industry-Leading Warranty**
2 years mechanical + 2 years electrical & hydraulic, parts and labor.
- **Pressure Compensated Flow Valve**
Constant, controlled speeds at all times. Prevents "free-fall" under certain hydraulic failures.
- **Anthony 3-Step Powder Coat**
Steel components are washed, shot blast prepped, and coated with premium finish.
- **Max Duty Dock Bumpers**
Helps protect floor extension from contact with dock. Includes rubber bumpers.

QUALITY COMES STANDARD

AVAILABLE MODELS, PLATFORMS AND CAPACITIES

Model	AST-1500	AST-2000	AST-2500	AST-3000	AST-3500
Capacity (lbs)	1500	2000	2500	3000	3500
Bed Height Range	42" - 57"				
Available Platforms					
Steel or Aluminum 80" x 38" + 5" Ramped					
Steel or Aluminum 80" x 45" + 6" Ramped					
Steel or Aluminum 80" x 50" Wedge*					
Steel or Aluminum 80" x 48" + 12" ARR					

Model	ASTL-1800	ASTL-2500
Capacity (lbs)	1800	2500
Bed Height Range	36" - 44"	
Available Platforms		
Steel 80" x 44" Wedge (standard)		
Aluminum 80" x 44" Wedge		

*Cart stops available. 39" load area when deployed.

OPTIONS

- Cart stops
- Power down
- Alternate floor extensions: 3/16", 1/4", or 3/8" steel. 96" or 102" Wide
- Wireless, removable handheld corded, flush mount, or dual control options.
- Stainless steel toggle switch guard
- Third step add-on for dock bumper
- Galvanized finish with extended warranty
- ICC bumper
- Cab or ignition cutoff switch
- 5 & 12 ton pintle hook / ball hitch brackets
- Walkramp capability
- Battery box

TRUCK MOUNTING REQUIREMENTS

A	B	C	
Bed Height	Bed to Top of Tube Assembly	Mounting Plate	
36" - 41"	15 3/4"	29"	
42" - 49"	19"	24 1/4"	
50" - 51"	20"	23 3/4"	
52" - 53"	21"	23 1/4"	
54" - 55"	22"	22 5/8"	
56" - 57"	23"	22 1/2"	

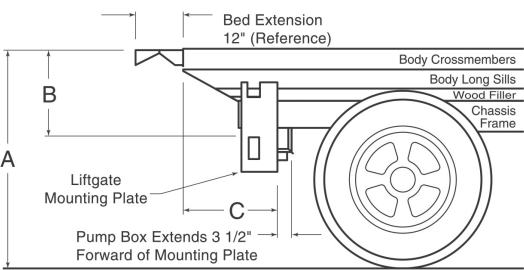

The diagram illustrates the truck mounting requirements with the following labels and dimensions:

- A:** Total height from the liftgate mounting plate to the top of the tube assembly.
- B:** Height from the liftgate mounting plate to the top of the tube assembly.
- C:** Distance from the liftgate mounting plate to the center of the wheel.
- Bed Extension:** 12" (Reference)
- Body Crossmembers**
- Body Long Sills**
- Wood Filler**
- Chassis Frame**
- Liftgate Mounting Plate**
- Pump Box Extends 3 1/2" Forward of Mounting Plate**

Anthony Liftgates, Inc.

1037 W. Howard Street
P.O. Box 615
Pontiac, IL 61764-0615

Phone: 815.842.3383

Fax: 815.844.3612

Toll Free: 800.482.0003

www.anthonyliftgates.com