

**ANTHONY**  
LIFTGATES, INC.®

**MTU-GLR**



\*Shown with optional features.

**MAGNUM TUCKUNDER™**

LIFTING CAPACITIES (LBS):  
2500, 3000, 4000, 5000, 6000

## KEY ADVANTAGES

- **GLR - Gentle Level Ride**  
Smooth, level up-down operation. Platform tilts gently at ground and re-levels before lifting cycle begins.
- **Twin Cylinder Drive**  
Powerful lift with low pressure helps to extend hydraulic component life.
- **Wedge Platform**  
Wedge design provides easy, secure loading.
- **Power Down**  
Reliable cycle time in all weather conditions.
- **Lifetime Warrantied Service Free Bushings**  
Used at all critical pivot points to reduce wear without the need for routine lubrication.

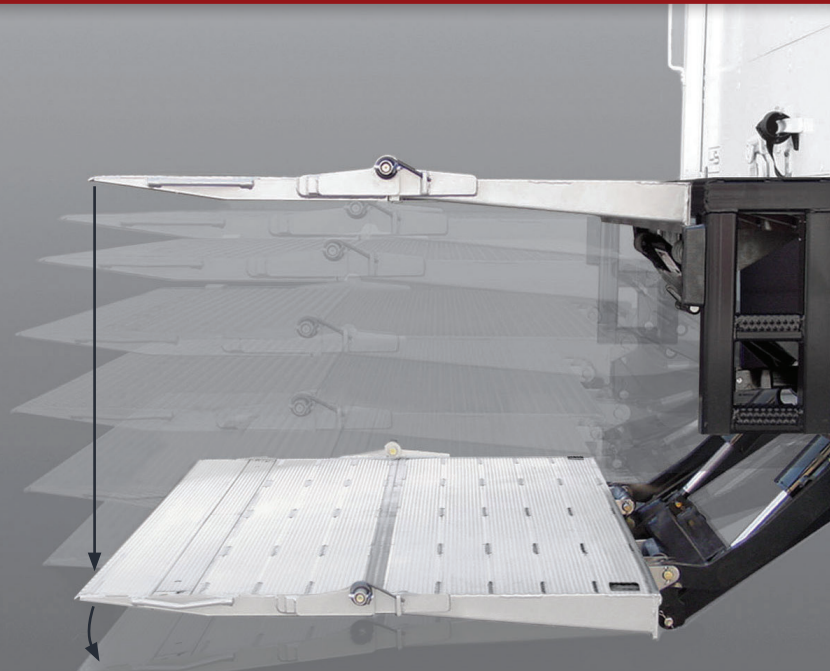

**QUALITY, RELIABILITY, CUSTOMER SERVICE**

**MADE IN THE USA** 



# STANDARD FEATURES

- **Spring Assist Platform**  
Dual torsion springs provide effortless platform operation.
- **Ground Contact Rollers**  
Rollers prevent scraping damage to liftgate and concrete or asphalt.
- **HD Mechanical Safety Latch**  
Redundant-system stowage in addition to hydraulic lock.
- **Max Duty Dock Bumpers**  
Helps protect floor extension from contact with dock. Includes rubber bumpers.
- **EZ Mount**  
Ships factory assembled, filled, and tested with notched center mark for easy installation. Floor extension may be bolted to the truck.
- **Circuit Protection**  
200 Amp fuse protects truck wiring from a "dead short".
- **CHS - Centralized Hydraulic System**  
All sensitive hydraulic and electrical components housed safely within the stainless steel pump box.
- **Marine Duty Potted Toggle Switch**  
Heavy duty toggle, potted to permanently separate and seal electrical connections from corrosion.
- **3/16" Steel Floor Extension**  
Rugged and attractive surface.
- **Industry-Leading Warranty**  
3 years mechanical + 3 years electrical & hydraulic, parts and labor.
- **Pressure Compensated Flow Valve**  
Constant, controlled speeds at all times. Prevents "free-fall" under certain hydraulic failures.
- **Cab Cutoff Switch**  
Prevents unauthorized liftgate operation.
- **Anthony 3-Step Powder Coat**  
Steel components are washed, shot blast prepped, and coated with premium finish.

## QUALITY COMES STANDARD

### AVAILABLE MODELS, PLATFORMS AND CAPACITIES

Model	Capacity (lbs)	Bed Height Range
MTU-GLR-25	2500	47" - 57"
MTU-GLR-3	3000	47" - 57"
MTU-GLR-4	4000	47" - 57"
MTU-GLR-5	5000	47" - 57"
MTU-GLR-6	6000	47" - 57"
Available Platforms		
Steel Main/Aluminum Flip 80" x 60" Wedge		
All Aluminum 80" x 60" Wedge*		

\*Not available on MTU-GLR-6.

### OPTIONS

- Alternate floor extensions: 3/16", 1/4", or 3/8" steel. 96" or 102" Wide.
- Wireless, removable handheld corded, flush mount, or dual control options.
- Stainless steel toggle switch guard
- Stainless steel battery box
- Trail Charger, solar charging
- Third step add-on for dock bumper
- Galvanized finish with extended warranty
- ICC bumper - trailer certified
- Ignition cut-off switch
- Trailer sub-frame mounting kit
- Dual, foot-operated cart stops

### TRUCK MOUNTING REQUIREMENTS

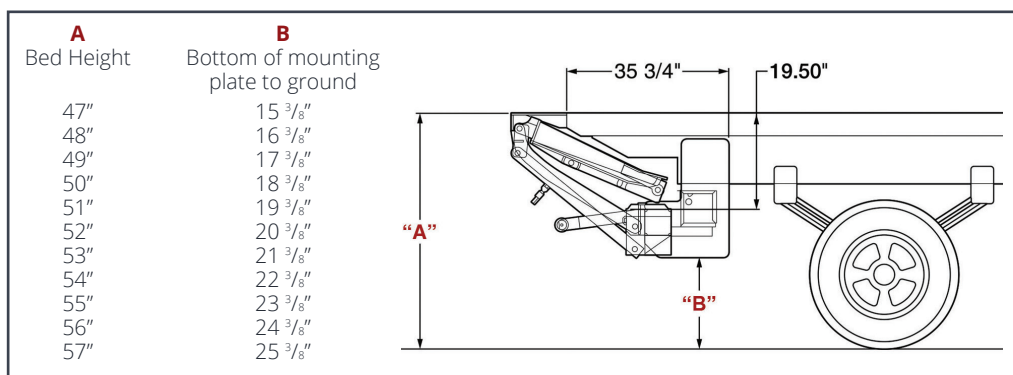

### Anthony Liftgates, Inc.

1037 W. Howard Street  
P.O. Box 615  
Pontiac, IL 61764-0615

**Phone:** 815.842.3383

**Fax:** 815.844.3612

**Toll Free:** 800.482.0003

**www.anthonyliftgates.com**