

TUK-A-WAY® SERIES

The TE-20 Series

MAXON®

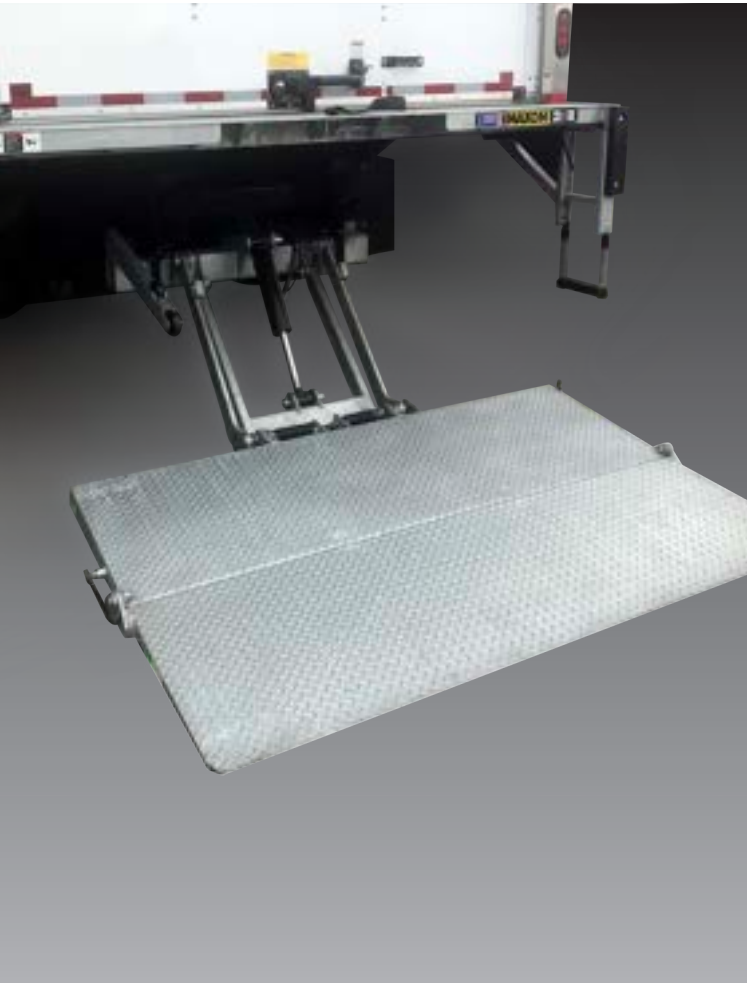

TE-20 SPECIFICATIONS

The TE-20 Series of Tuk-A-Way® liftgates are the economical choice for general purpose applications requiring 2,000 lbs. lifting capacity. The minimum laden bed height of 36" makes the TE-20 an ideal solution for low bed height applications.

- Center Arm Design
- SmartSpace™ - gap between extension plate and platform that mitigates a potential pinch point
- Standard Ride
- Low Bed Height Compatible
- 38 Foot Charge Line Kit with a Circuit Breaker

MODEL CAPACITY	WEDGE PLATFORM SIZE	TOTAL WEIGHT	BED HEIGHT
TE-20 (2,000 Lbs.)	36" x 80" (ST) 40" x 80" (AL)	550 lbs. to 585 lbs.	42" Min. w/Body Laden 54" Max. w/Body Unladen
TE-20L (2,000 Lbs.)			36" Min. w/Body Laden 44" Max. w/Body Unladen

ST = Steel
AL = Aluminum

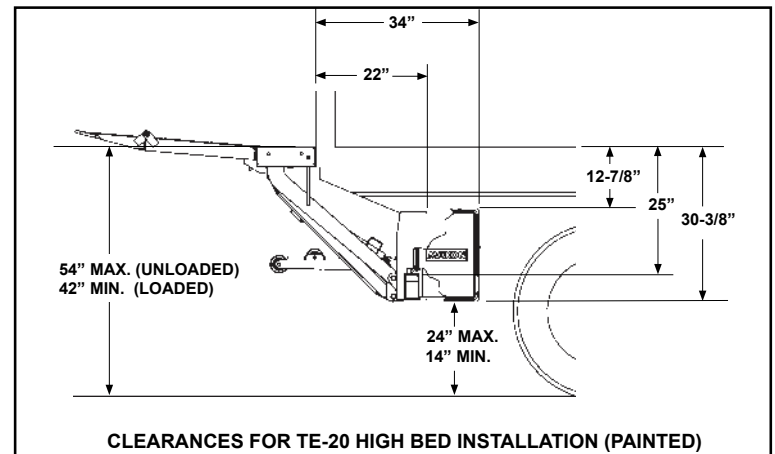
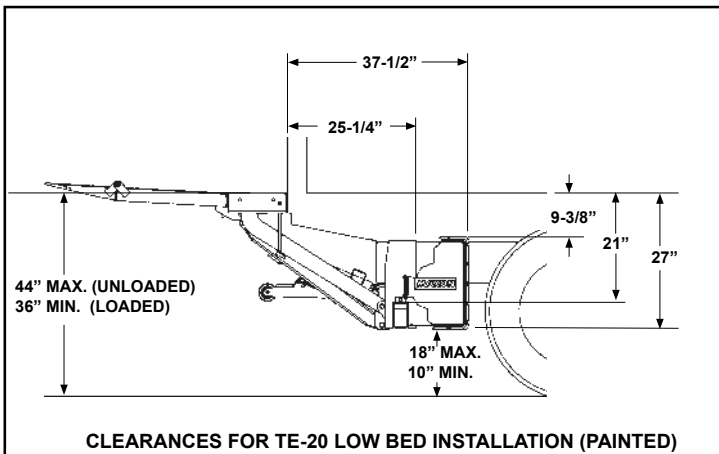

Lift Dimensions and Mounting Requirements

NOTE: Please review appropriate liftgate installation manual for full vehicle and or body requirements to ensure proper fitment.



Maxon Lift Corp. 11921 Slauson Ave., Santa Fe Springs, CA 90670
800.227.4116 Fax 888.771.7713, www.maxonlift.com

TUK-A-WAY® SERIES

The TE-20 Series

MAXON®

Optional Features

- Dual Cart Stops
- Bolt-on steps
- Heavy-Duty Dock Bumpers
- Bumper Pads
- MAX ECU® (Electrical Control Unit)
- Street Side Controls
- Power Down
- Galvanized Finish

Loadable Platform Space with Cart Stops Deployed

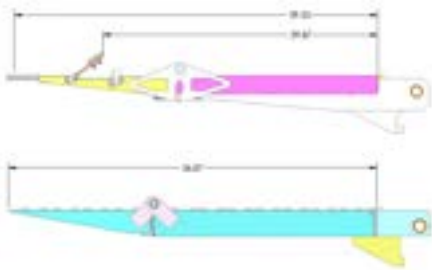

Distributed by:

M225-0523



Large Wedge-Type Platform Design

The TE-20 features large (36"/40"x 80") wedge-type platforms that are available in Steel or Aluminum configurations. The wedge design allows for the smooth transition of load on and off the platform.

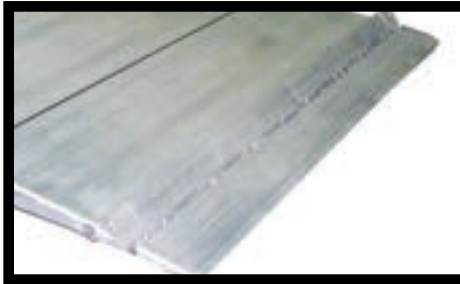

Dual Cart Stop Options

The Aluminum platforms feature dual cart stops.



Optional Bolt-On Steps and Extension Plate

The steps and extension plates were strategically designed to bolt-on (option) in order to avoid welding on the gate that would affect the factory paint or galvanized finish. The steps were also designed as an integral part of the gate that would easily allow for them to be exchanged in case of dock damage.



Grease Fittings Standard

The TE-20 features grease fittings at all critical rotation points.



MAXPRO® Paint or GALVANIZED Finish

This patented, Maxon exclusive paint process has a tough polyurea top coat and an AL rich primer that combat corrosion and keep the liftgate looking like new for many years. For even more corrosion protection, the TE-20 is also available in a galvanized finish.



Maxon Lift Corp. 11921 Slauson Ave., Santa Fe Springs, CA 90670
800.227.4116 Fax 888.771.7713, www.maxonlift.com