



VAN PARTITIONS

Our safety partitions protect the most important asset: You!

VAN PARTITIONS – CONTOURED

VAN PARTITIONS

CONTOURED

CONTOURED MAX VIEW



3320-FTL

Ford Transit
Max View contoured safety partition

Composite

	Low Roof
	50 lbs
	1.5 hr
	Yes
	8"



3320-MM

Mercedes-Benz Metris
Max View contoured safety partition

Composite

	Standard Roof
	48 lbs
	1.2 hrs
	Yes
	9"



3320-PC

Ram ProMaster City
Max view contoured safety partition

Composite

	Standard Roof
	42 lbs
	1 hr
	Yes
	7.1"





3520-M

All Standard Minivans
ClearView germ barrier partition for minivans

Composite

	Standard Minivans
	10 lbs
	0.25 hr
	No
	-

CONTOURED COMPOSITE



3310-DH

Mercedes-Benz Sprinter
Composite contoured safety partition

Composite

	High Roof
	70 lbs
	1 hr
	Yes
	9"



3310-DL

Mercedes-Benz Sprinter
Composite contoured safety partition

Composite

	Low Roof
	65 lbs
	1 hr
	Yes
	9"



3310-GS

Chevrolet Express, GMC Savana
Composite contoured safety partition

Composite

	Standard
	47 lbs
	0.80 hr
	Yes
	9"



3310-FTH

Ford Transit
Composite contoured safety partition

Composite

	High Roof
	66 lbs
	1 hr
	Yes
	9"

VAN PARTITIONS – CONTOURED



3310-FTM

Ford Transit
Composite contoured safety partition

Composite

Medium Roof

63 lbs

1 hr

Yes

9"



3310-PC

Ram ProMaster City
Contoured safety partition

Composite

Standard Roof

44 lbs

1 hr

No

7.1"



3310-RP

Ram ProMaster
Composite contoured safety partition

Composite

Standard/High Roof

64 lbs

1 hr

Yes

9"



3320-DH

Mercedes-Benz Sprinter
Composite contoured safety partition
with window

Composite

High Roof

71 lbs

1 hr

No

9"



3320-DL

Mercedes-Benz Sprinter
Composite contoured safety partition
with window

Composite

Low Roof

67 lbs

1 hr

No

9"



3320-GS

Chevrolet Express, GMC Savana
Composite contoured safety partition
with window

Composite

Standard

48 lbs

0.80 hr

Yes

9"



3320-FTH

Ford Transit

Composite contoured safety partition with window

Composite

High Roof

68 lbs

1 hr

No

9"



3320-FTM

Ford Transit

Composite contoured safety partition with window

Composite

Medium Roof

65 lbs

1 hr

No

9"



3320-RP

RAM ProMaster

Composite contoured safety partition with window

Composite

Standard/High Roof

68 lbs

1 hr

No

9"

CONTOURED WITH WINDOW



3020-DH

Mercedes-Benz Sprinter

Contoured safety partition with window

Aluminum

High Roof

66 lbs

1.2 hrs

No

5.5"



3020-DL

Mercedes-Benz Sprinter

Contoured safety partition with window

Aluminum

Low Roof

64 lbs

1.2 hrs

No

5.5"

VAN PARTITIONS – CONTOURED



3020-FTH

Ford Transit
Contoured safety partition with window

Aluminum

	High Roof
	66 lbs
	1 hr
	Yes
	8.32"



3020-FTL

Ford Transit
Contoured safety partition with window

Aluminum

	Low Roof
	48 lbs
	1 hr
	Yes
	7.16"



3020-FTM

Ford Transit
Contoured safety partition with window

Aluminum

	Medium Roof
	52 lbs
	1 hr
	Yes
	8.32"



3020-GS

Chevrolet Express, GMC Savana
Contoured safety partition with window

Aluminum

	Standard Roof
	49 lbs
	1 hr
	No
	5.56"



3020-PC

Ram ProMaster City
Contoured safety partition with window

Aluminum

	Standard Roof
	41 lbs
	1 hr
	Yes
	8.1"

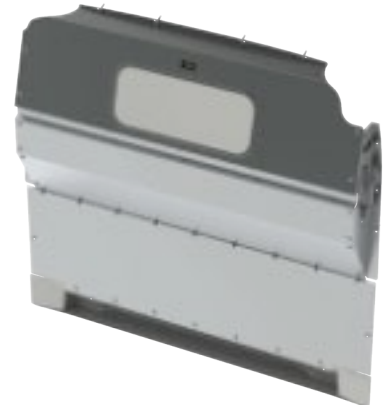

3020-RP

Ram ProMaster
Contoured safety partition with window

Aluminum

	Standard / High Roof
	59 lbs
	1 hr
	Yes
	6.07"

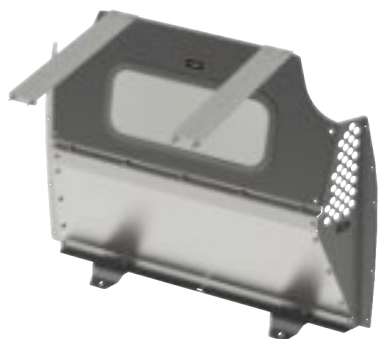

3020-TC

Ford Transit Connect
Contoured safety partition with window

Aluminum

Standard Roof

42 lbs

1 hr

Yes

10.75"

**SETBACK FROM
B PILLAR**

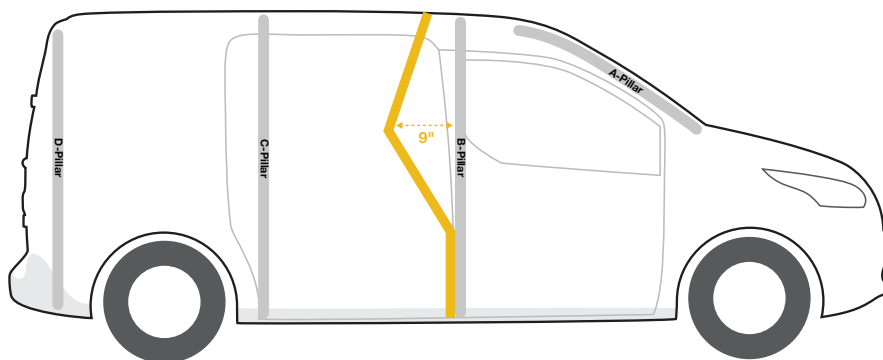

**CONTOURED
WITH
PERFORATED
WINDOW**



C10-E

Ford Transit Connect
Contoured safety partition
with perforated window

Steel

Standard Roof

53 lbs

1 hr

Yes

10.5"



C10-FTL

Ford Transit
Contoured safety partition
with perforated window

Steel

Low Roof

66 lbs

1 hr

Yes

7.11"

VAN PARTITIONS – CONTOURED



C10-H

Chevrolet Express, GMC Savana
Contoured safety partition with perforated window

Steel

	Standard Roof
	58 lbs
	1 hr
	Yes
	5.56"



C10-MM

Mercedes-Benz Metris
Contoured safety partition with perforated window

Steel

	Standard Roof
	62 lbs
	1 hr
	Yes
	11"



C10-PC

Ram ProMaster City
Contoured safety partition with perforated window

Steel

	Standard Roof
	63.3 lbs
	1 hr
	Yes
	8.05"



C10-W

Nissan NV200
Contoured safety partition with perforated window

Steel

	Standard Roof
	42 lbs
	1 hr
	Yes
	3.5"



CONTOURED FULL PARTITION

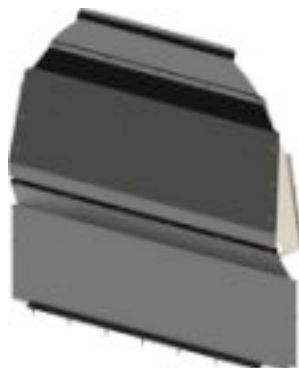

3010-DH

Mercedes-Benz Sprinter
Contoured safety partition

Aluminum

High Roof

59 lbs

1.2 hrs

Yes

5.5"

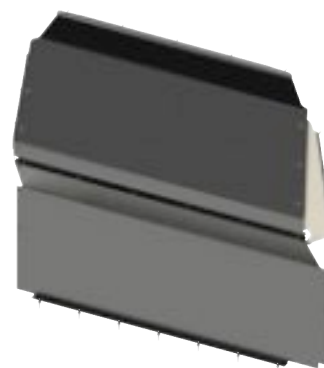

3010-DL

Mercedes-Benz Sprinter
Contoured safety partition

Aluminum

Low Roof

57 lbs

1.2 hrs

No

5.5"



3010-FTH

Ford Transit
Contoured safety partition

Aluminum

High Roof

57 lbs

1 hr

Yes

8.32"



3010-FTL

Ford Transit
Contoured safety partition

Aluminum

Low Roof

46 lbs

1 hr

Yes

7.16"



3010-FTM

Ford Transit
Contoured safety partition

Aluminum

Medium Roof

52 lbs

1 hr

Yes

8.32"

VAN PARTITIONS – CONTOURED

VAN PARTITIONS



3010-GS

Chevrolet Express, GMC Savana
Contoured safety partition

Aluminum

Standard Roof

47 lbs

1 hr

Yes

5.56"



3010-PC

Ram ProMaster City
Contoured safety partition

Aluminum

Standard Roof

39 lbs

1 hr

Yes

8.1"



3010-RP

Ram ProMaster
Contoured safety partition

Aluminum

Standard / High Roof

62.8 lbs

1 hr

Yes

6.07"



3010-TC

Ford Transit Connect
Contoured safety partition

Aluminum

Standard Roof

39.75 lbs

1 hr

Yes

10.75"



C12-E

Ford Transit Connect
Contoured safety partition

Steel

Standard Roof

55 lbs

1 hr

Yes

10.5"



C12-FTL

Ford Transit
Contoured safety partition

Steel

Low Roof

64 lbs

1 hr

Yes

7.11"



C12-H

Chevrolet Express, GMC Savana
Contoured safety partition

Steel

Standard Roof

53 lbs

1 hr

No

5.56"



C12-PC

Ram ProMaster City
Contoured safety partition

Steel

Standard Roof

86 lbs

1 hr

Yes

8.05"

CONTOURED WIRE MESH



C13-E

Ford Transit Connect
Contoured wire mesh partition

Steel

Standard Roof

37 lbs

0.7 hr

Yes

10.5"

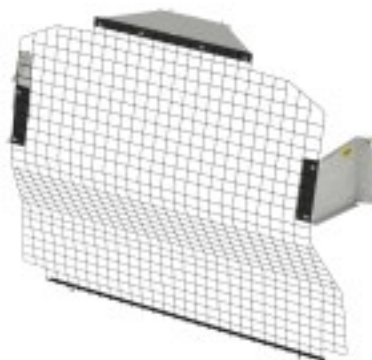

C13-MM

Mercedes-Benz Metris
Contoured wire mesh partition

Steel

Standard Roof

37 lbs

1.2 hrs

Yes

11"



C13-PC

Ram ProMaster City
Contoured wire mesh partition

Steel

Standard Roof

72 lbs

1 hr

Yes

8.33"

VAN PARTITIONS – CONTOURED

STRAIGHT

STRAIGHT WITH PERFORATED WINDOW — NO ACCESS



C20-DH

Mercedes-Benz Sprinter

Straight partition with perforated window, no access

Steel

High Roof

89 lbs

1 hr

Yes

7.5"



C20-DL

Mercedes-Benz Sprinter

Straight partition with perforated window, no access

Steel

Low Roof

80 lbs

1 hr

Yes

7.5"



C20-FTH

Ford Transit

Straight partition with perforated window, no access

Steel

High Roof

92.1 lbs

1 hr

Yes

4.76"



C20-FTL

Ford Transit

Straight partition with perforated window, no access

Steel

Low Roof

64 lbs

1 hr

Yes

4.25"

VAN PARTITIONS – CONTOURED



C20-FTM

Ford Transit

Straight partition with perforated window, no access

Steel

Medium Roof

77 lbs

1 hr

Yes

4.76"



C20-GS

Chevrolet Express, GMC Savana

Straight partition with perforated window, no access

Steel

Standard Roof

61 lbs

1.5 hr

Yes

6.75"



C20-NH

Nissan NV

Straight partition with perforated window, no access

Steel

High Roof

80 lbs

1.5 hrs

Yes

5.5"



C20-NL

Nissan NV

Straight partition with perforated window, no access

Steel

Low Roof

58 lbs

1 hr

Yes

5.5"

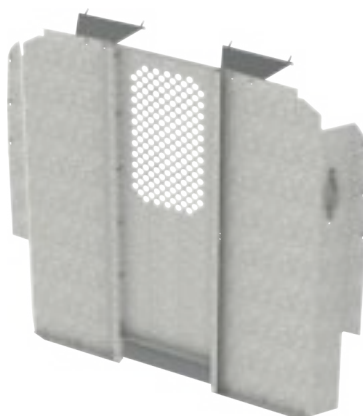

C20-X

Ram ProMaster

Straight partition with perforated window, no access

Steel

Standard / High Roof

78 lbs

1 hr

Yes

6.24"



VAN PARTITIONS – STRAIGHT

VAN PARTITIONS

STRAIGHT WITH PERFORATED WINDOW — SWING DOOR



C30-DH

Mercedes-Benz Sprinter
Straight partition with perforated window, swing door

Steel

High Roof

92 lbs

1 hr

No

8"



C30-DL

Mercedes-Benz Sprinter
Straight partition with perforated window, swing door

Steel

Low Roof

83 lbs

1 hr

No

8"



C30-FTH

Ford Transit
Straight partition with perforated window, swing door

Steel

High Roof

86 lbs

1.5 hrs

Yes

4.96"



C30-FTL

Ford Transit
Straight partition with perforated window, swing door

Steel

Low Roof

68 lbs

1.5 hrs

Yes

4.61"



C30-FTM

Ford Transit
Straight partition with perforated window, swing door

Steel

Medium Roof

79 lbs

1.5 hrs

Yes

4.96"



C30-GS

Chevrolet Express, GMC Savana
Straight partition with perforated window, swing door

Steel

Standard Roof

63.2 lbs

1 hr

Yes

6.75"

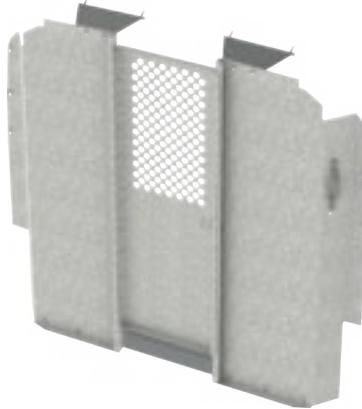

C30-X

Ram ProMaster
Straight partition with perforated window, swing door

Steel

Standard / High Roof

80 lbs

1 hr

Yes

6.24"



STRAIGHT WITH WINDOW — SLIDING DOOR



3068-DH

Mercedes-Benz Sprinter
Straight partition with window, sliding door

Aluminum

High Roof

97.9 lbs

1.5 hrs

Yes

8"



3068-DL

Mercedes-Benz Sprinter
Straight partition with window, sliding door

Aluminum

Low Roof

84 lbs

1.5 hrs

Yes

7.25"

VAN PARTITIONS – STRAIGHT

VAN PARTITIONS



3068-FTH

Ford Transit

Straight partition with window, sliding door

Aluminum

High Roof

77 lbs

1.5 hrs

Yes

6.29"



3068-FTM

Ford Transit

Straight partition with window, sliding door

Aluminum

Medium Roof

75 lbs

1.5 hrs

Yes

6.29"



3068-RP

Ram ProMaster

Straight partition with window, sliding door

Aluminum

Standard / High Roof

76 lbs

1.5 hrs

Yes

6.26"

STRAIGHT MID POSITION



3015-DH

Mercedes-Benz Sprinter

Mid position straight safety partition

Aluminum

High Roof

59 lbs

1.2 hrs

No

2.5"



3025-DH

Mercedes-Benz Sprinter

Mid position straight safety partition with window

Aluminum

High Roof

66 lbs

1.2 hrs

No

2.5"

ACCESSORIES



3024

Universal
Partition window with frame
for 3010

Aluminum

Universal
5 lbs
0.2 hr
No

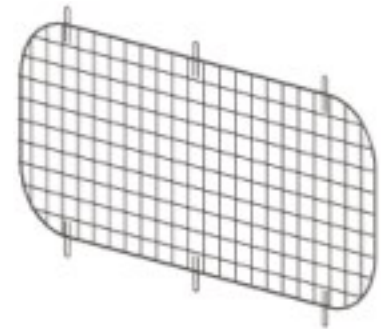

3044

Universal
Grill for partition window
for 3020, 3025, 3068

Steel

Universal
2 lbs
0.5 hr
No

WALK THROUGH



C24-DH

Mercedes-Benz Sprinter
Straight walk through partition

Steel

High Roof
66 lbs
1 hr
No
7.5"

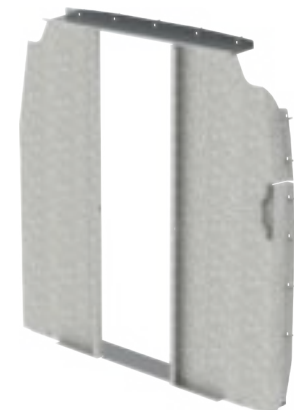

C24-DL

Mercedes-Benz Sprinter
Straight walk through partition

Steel

Low Roof
61 lbs
1 hr
No
7.5"

VAN PARTITIONS – STRAIGHT



C24-FTH

Ford Transit
Straight walk through partition

Steel

High Roof
65 lbs
1.2 hrs
Yes
4.76"



C24-FTL

Ford Transit
Straight walk through partition

Steel

Low Roof
48 lbs
1.2 hrs
Yes
4"



C24-FTM

Ford Transit
Straight walk through partition

Steel

Medium Roof
58 lbs
1.2 hrs
Yes
4.76"



C24-GS

Chevrolet Express, GMC Savana
Straight walk through partition

Steel

Standard Roof
46.5 lbs
1 hr
Yes
6.75"



C24-X

Ram ProMaster
Straight walk through partition

Steel

Standard / High Roof
70 lbs
1 hr
Yes
6.24"



VAN PARTITIONS – STRAIGHT

