

SPRINTER | TRANSIT | ENCLOSED SERVICE BODIES

VENTURO™ VAN CRANES



VENTURO

VAN CRANES



VENCO VENTURO INDUSTRIES LLC
WWW.VENTURO.COM



CREATING A NEW LIFTING SOLUTION FOR YOUR WORK VAN

As one of the founding members of NTEA, Venco Venturo has developed a specialized line of high-quality service truck cranes, dump hoists and crane service bodies for over 50 years. Throughout the industry, the changing dynamics of work equipment has led to Venturo's newest product line, the Venturo Van Cranes.

These line of products have revolutionized the work van market. Van fleets, operators and contractors have always required a lifting solution for anything such as air conditioning units, plumbing equipment, electrical contracting equipment, auto parts delivery, oil/gas delivery and much more.

Designed and engineered with storage and floor space in mind, these van cranes offer a high-capacity solution for any jobsite.

Contact your local distributor of Venturo Van Cranes for a solution to your work van needs.





THE VENTURO ADVANTAGE!

1. EASY INSTALLATION

Easily install all models of our van cranes. With step-by-step instructions, you can upfit any of our vans quickly and easily.

2. CONSOLIDATE YOUR FLEET

Add a crane to your work vans to turn them into the ultimate workspace on wheels. You will no longer need additional vehicles for separate material handling functions.

3. INCREASE PRODUCTIVITY

Save employee time, energy and help prevent workplace injuries with a safe and efficient lifting solution.

4. MULTIPLE UPFIT CONFIGURATIONS

Plenty of options to choose from, whether a Ford Transit, Mercedes Sprinter or a variety of enclosed utility bodies. You can even choose from a side-door mount or rear-mount for your van!



Simplifying Safety: Work Van Crane Helps Keep the South Well- Lubricated

Parker Oil is a family owned and operated business located in North Georgia. They deliver motor oil, lubricants, and other accessories to customers in North Georgia, North Carolina and South Carolina. Brent Parker, owner of Parker Oil, started the company in 2012. The business also includes his son-in-law, his wife,

his dad and a friend. Because Parker Oil is a wholesale distributor of bulk 55 gallon drums of oil and transmission fluid to auto repair shops and industrial customers, they needed a way to lift these very heavy products. A 55-gallon drum of oil weighs 400 pounds and one of antifreeze weighs 500 pounds. In the past, Parker Oil used box trucks and a lift gate, but

that still meant that their workers had to wrestle the drums into the truck, which could be less safe as well as physically challenging for them. Parker Oil purchased the Venturo VC1000 Van Crane mounted within the Ford Transit. With the crane, Parker and his team can load a drum into the van without having to touch it. Parker also notes that the crane is half the price of a lift gate.

Parker worked with his Ford dealer Jackie Jones Ford in Cleveland, GA to design the perfect Transit for this special use. He selected the tallest and longest dual wheel Transit 350. "This is a great van," said Parker. "Not only is it the best design for the purpose, my box trucks were only getting 8 miles to the gallon and the Transit averages 30!"

"Operators can guide the load easily in and out of the van," said Parker. "Safety, ease of use and lower costs were the right trifecta for Parker Oil."



The Best of Both Worlds

Automotive Parts Solutions, Inc. (APS) located in the Rockville – St. Cloud area of **Minnesota** is a supplier of used auto parts to insurance companies, collision centers and auto repair facilities throughout Minnesota, North Dakota, South Dakota, Wisconsin, and Iowa. APS is an URG 8000 certified and CAR Gold Seal certified recycler, which guarantees customers accurate part descriptions, quality auto parts, and professional service. Robert Witzmann, operations manager, for Automotive Parts Solutions manages the recycling yard as well as the sale of drive train engines and transmissions. While many of the delivery vans are cube vans with heavy, expensive lift gates, Witzmann needed a crane solution for a medium-sized Ford Transit. Hydraulic lifts wouldn't work as the only installation option was an expensive lift on the side that would be in the way and the customization required would have made one of the doors unusable since the doors fold back against the body of the van.

"We use the Ford Transit for short runs and customer visits, and the van crane enables us to deliver engines and transmissions and other heavy items," said Witzmann. "It is convenient to have the crane available without having to drive a large cube van."

Witzmann said Venco Venturo helped customize the VC1000 crane to meet the needs of APS and that it works very well. "When we need to use it, we hop in the smaller transit vehicle and are able to use it like full-size truck and lift diesel engine transmission combinations with it. It is very secure, swings and pivots nicely and it doesn't move around. It is very easy to use," said Witzmann. "It handles everything we need. We can deliver things we wouldn't be able to deliver without the crane and it rides like big mini van when we're not using the crane so it is the best of both worlds."

The crane folds up compactly against the wall and is protected from the weather. "The van crane only takes up about 10" x 10" of floor space behind the wheel well and we can still get a sheet of plywood in there so realistically it takes up no usable floor space. There is a basket for the controls and it tucks nicely out of the way when we're not using it," said Witzmann. "Safety bars can get salt and debris in them, and this crane always looks brand new since we don't have to worry about weather conditions affecting it." The VC1000 crane has required little maintenance in the nearly two years APS has used it. "We have had no issues with our work van crane," Witzmann said. "Venco Venturo has great customer service and has really taken care of us. The VC1000 has really been a good piece of machinery for us and we can always count on it to work."

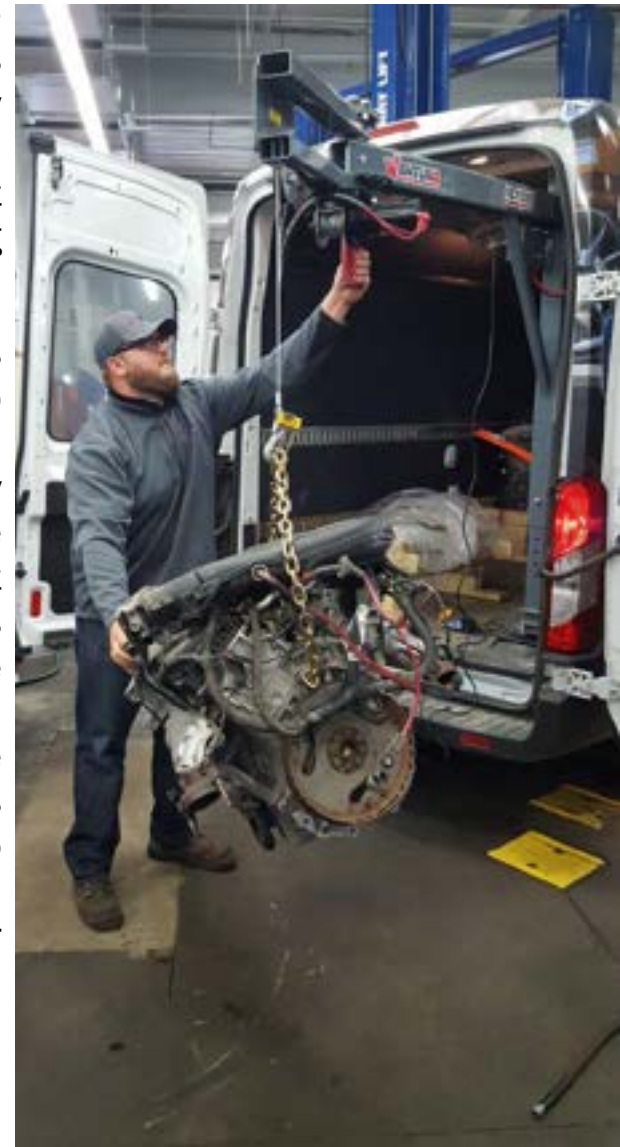



A NEW ERA OF CRANE

The newest addition to the product lines include the all-new Venturo VC1000 Van Crane for the Ford Transit and Mercedes-Benz Sprinter models. This crane is revolutionary in the industry for its maximum weight capacity of 1,000 LBS and reach of 6 FT for the work van market. The crane utilizes a unique dual floor and ceiling mounted telescopic mast that integrates with the van structure itself to ensure maximum structural integrity.

The telescopic mast will allow it to fit within the Transit Mid & High Roof and also Sprinter Standard & High Roof models. The crane also features two unique rotation control features for the primary and secondary booms which utilize two hand levers that operate multi-positional locks. This key feature adds an additional safeguard for the operators as the load is being loaded and unloaded. The Venturo VC1000 allows safe and productive material handling without the need for a forklift or a heavy, expensive liftgate.

**CONSTRUCTION
EQUIPMENT**
Top 100 2016
new products



FORD TRANSIT VC1000 MID/HIGH ROOF

SPECIFICATIONS

MAXIMUM CAPACITY:	1,000 LBS
CRANE RATING:	6,000 FT-LBS
MAST HEIGHT:	TELESCOPIC
EXTENDED BOOM REACH:	6 FT
RETRACTED BOOM LENGTH:	4 FT, 6 IN
WEIGHT:	350 LBS
TOP BRACKET:	13" X 14.3"
BASE PLATE:	10" X 10"
WINCH:	12V DC, 1.3 HP MOTOR WITH 25' OF 3/16" WIRE ROPE, 25.5 FPM

STANDARD FEATURES

- MASTER DISCONNECT SWITCH KIT
- 12 FT PENDANT CONTROLLER
- BATTERY CABLES WITH GROUND WIRE
- MOUNTING HARDWARE WITH FLOOR CHANNEL SHIMS
- TELESCOPIC MAST FOR MULTIPLE ROOF HEIGHTS
- TOP MOUNTING BRACKET FOR TRANSIT
- MAIN BOOM ROTATION LOCK
- SECONDARY BOOM ROTATION LOCK
- SINGLE HAND-CRANK JACKLEG OUTRIGGER

OPTIONS

- 150 AMP CIRCUIT BREAKER
- UNIVERSAL DRUM LIFTER (3RD PARTY)
- FORD CLASS III RECEIVER HITCH
- (JACKLEG OUTRIGGER REQUIRES CLASS III RECEIVER HITCH. CONTACT YOUR LOCAL EQUIPMENT UPFITTER FOR MORE INFORMATION)

FORD TRANSIT VC1000 PACKAGE COSTS

PART #	VGDAAA
MOUNTING KIT #	23367-2
CIRCUIT BREAKER KIT #	22946-150
PACKAGE COST	\$3,128.00

(Cost does NOT include freight/installation/taxes)

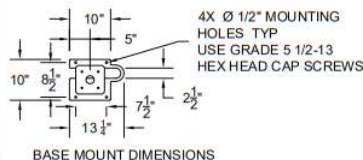
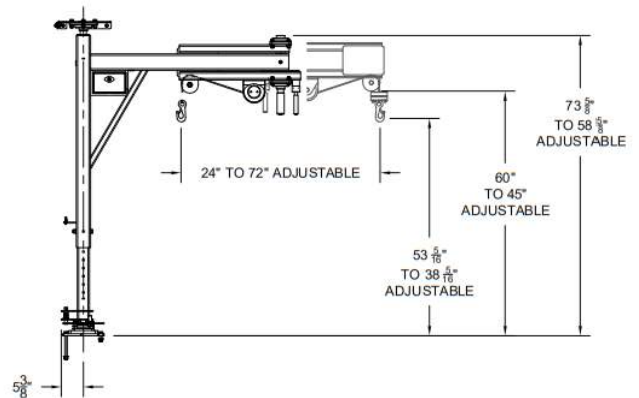
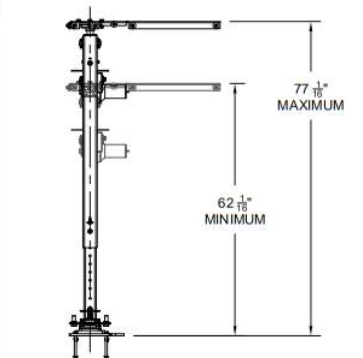
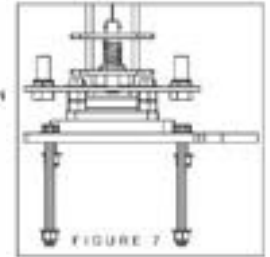
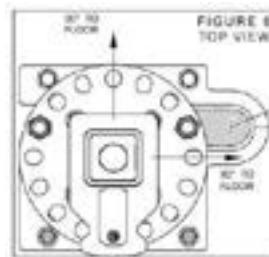
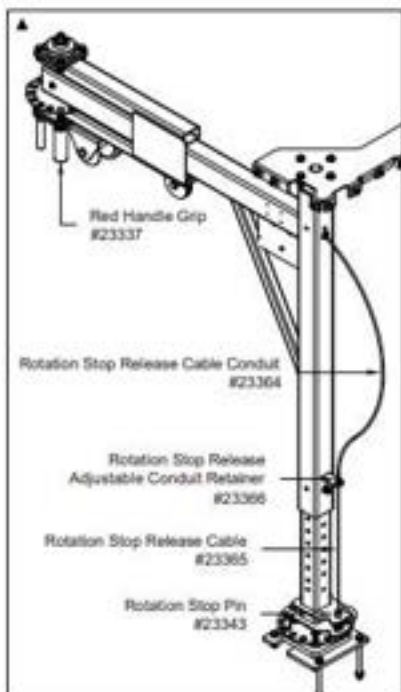

MERCEDES/FREIGHTLINER SPRINTER VC1000 STANDARD/HIGH ROOF

SPECIFICATIONS

MAXIMUM CAPACITY:	1,000 LBS
CRANE RATING:	6,000 FT-LBS
MAST HEIGHT:	TELESCOPIC
EXTENDED BOOM REACH:	6 FT
RETRACTED BOOM LENGTH:	4 FT, 6 IN
WEIGHT:	350 LBS
TOP BRACKET:	13" X 14.3"
BASE PLATE:	10" X 10"
WINCH:	12V DC, 1.3 HP MOTOR WITH 25' OF 3/16" WIRE ROPE, 25.5 FPM

STANDARD FEATURES

- MASTER DISCONNECT SWITCH KIT
- 12 FT PENDANT CONTROLLER
- BATTERY CABLES WITH GROUND WIRE
- MOUNTING HARDWARE WITH FLOOR CHANNEL SHIMS
- TELESCOPIC MAST FOR MULTIPLE ROOF HEIGHTS
- TOP MOUNTING BRACKET FOR SPRINTER
- MAIN BOOM ROTATION LOCK
- SECONDARY BOOM ROTATION LOCK
- SINGLE HAND-CRANK JACKLEG OUTRIGGER

OPTIONS

- 150 AMP CIRCUIT BREAKER
- UNIVERSAL DRUM LIFTER (3RD PARTY)
- SPRINTER CLASS III RECEIVER HITCH
- (JACKLEG OUTRIGGER REQUIRES CLASS III RECEIVER HITCH. CONTACT YOUR LOCAL EQUIPMENT UPFITTER FOR MORE INFORMATION)

SPRINTER VC1000 PACKAGE COSTS

PART #	VHDAAA
MOUNTING KIT #	23367-4
CIRCUIT BREAKER KIT #	22946-150
PACKAGE COST	\$3,128.00

(Cost does NOT include freight/installation/taxes)

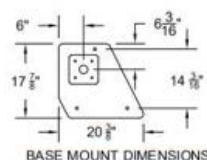
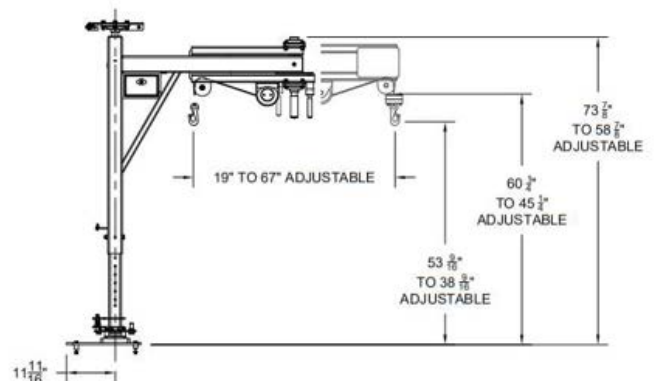
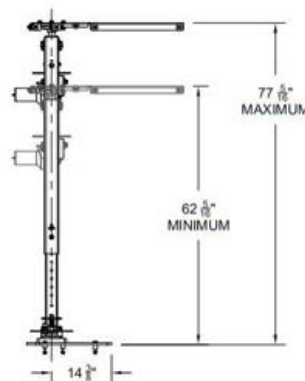
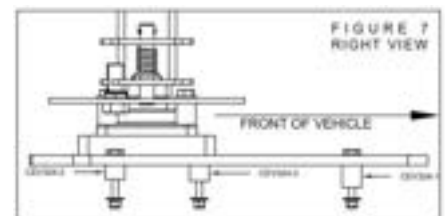
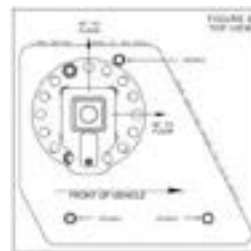
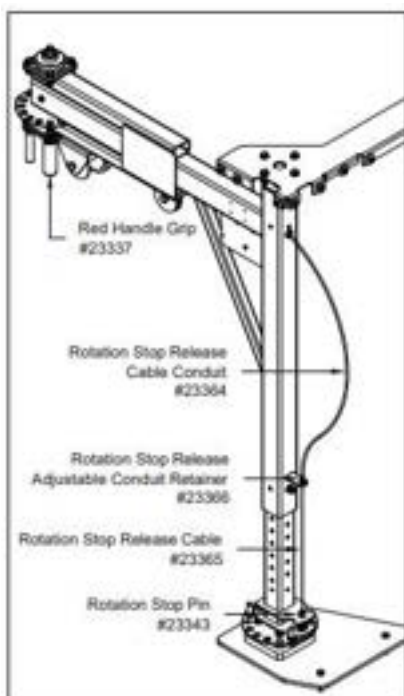



LIFTING SOLUTION FOR YOUR ENCLOSED SERVICE VAN

The ESV1000 now offers you a lifting solution for the jobsite with your enclosed service body. With an extremely small footprint, the crane can stow nicely against the inside wall on either the curb-side or street-side of the service body when not in use. With the telescopic boom, the ESV1000 can fit in any of the enclosed service bodies without the need for any add-ons or specialty mounting kits. The 12V DC winch wires directly to the battery and includes a 12 FT pendant controller with up/down functions. The winch is situated in a fixed housing to the side of the crane. This will allow the boom to swing with zero winch interference, giving the crane a wide swing radius.



ESV1000 ENCLOSED SERVICE/UTILITY BODY

SPECIFICATIONS

MAXIMUM CAPACITY:	1,000 LBS
CRANE RATING:	3,000 FT-LBS
MAST HEIGHT:	3 1/2 FT
EXTENDED BOOM REACH:	3 FT
RETRACTED BOOM LENGTH:	2 FT
WEIGHT:	200 LBS
BASE PLATE:	15" X 13"
WINCH:	12V DC, 1.3 HP MOTOR WITH 25' OF 3/16" WIRE ROPE, 25.5 FPM

STANDARD FEATURES

- MASTER DISCONNECT SWITCH KIT
- 12 FT PENDANT CONTROLLER
- BATTERY CABLES WITH GROUND WIRE
- FIXED MOUNTED WINCH

OPTIONS

- 150 AMP CIRCUIT BREAKER
- FORD TRANSIT UNIVERSAL BASE

ESV1000 PACKAGE COSTS

PART #	VKELAA (STREET-SIDE)
	VKERRA (CURB-SIDE)
CIRCUIT BREAKER KIT #	22946-150
PACKAGE COST	\$2,312.00

(Cost does NOT include freight/installation/taxes)

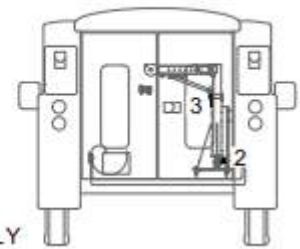
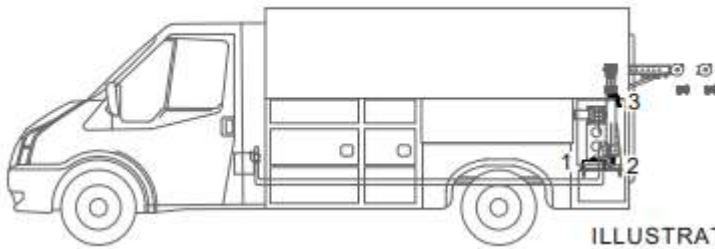

ILLUSTRATIONS FOR REFERENCE ONLY

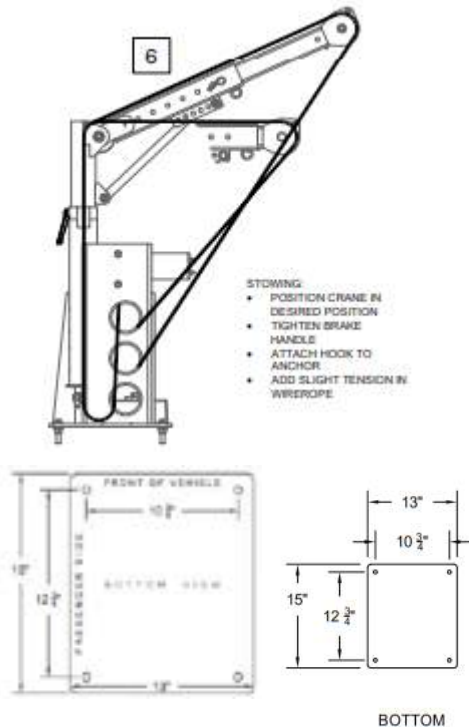

- STOWING:**
- POSITION CRANE IN DESIRED POSITION
 - TIGHTEN BRAKE HANDLE
 - ATTACH HOOK TO ANCHOR
 - ADD SLIGHT TENSION IN WIRE ROPE

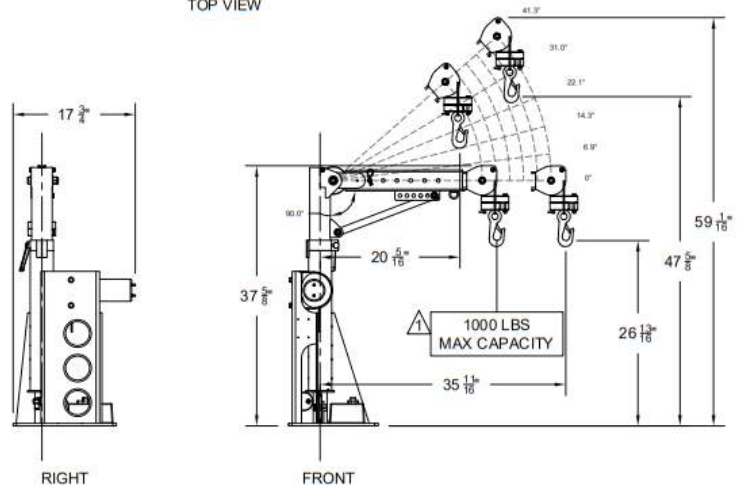
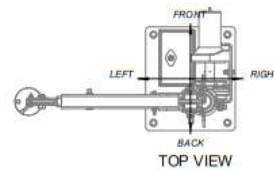



Equipment
TODAY
contractors'
**top
50**
NEW PRODUCTS
2017 AWARD WINNER

SMALLER CRANE FOR SMALLER OPENINGS

The VC750FB van crane includes a 2 ft, 6 in boom length with a maximum capacity of 750 lbs. for the Euro-style work van side-door. With a maximum capacity of 750 LBS and a reach up to 2 1/2 FT, the VC750FB is perfect for Ford Transit side-door applications. This crane takes up little space and the boom folds down allowing more cargo space. Fold-down boom offers a secure storage position and easy access to the cargo area of the van.

Note: 750 LBS maximum capacity is based on typical van floor structure limitations, not winch capacity. It is the sole responsibility of the installer to determine if additional floor reinforcement is necessary.



VC750FB SIDE-DOOR/REAR-MOUNT APPLICATION

SPECIFICATIONS

MAXIMUM CAPACITY:	750 LBS
CRANE RATING:	1,875 FT-LBS
MAST HEIGHT:	60 1/2 IN
EXTENDED BOOM REACH:	2 FT, 6 IN
WEIGHT:	165 LBS
BASE PLATE:	12" X 12"
WINCH:	12V DC, 1.3 HP MOTOR WITH 25' OF 3/16" WIRE ROPE, 25.5 FPM

STANDARD FEATURES

- MASTER DISCONNECT SWITCH KIT
- 12 FT PENDANT CONTROLLER
- BATTERY CABLES WITH GROUND WIRE
- REINFORCED BASE PLATE

OPTIONS

- 150 AMP CIRCUIT BREAKER
- UNIVERSAL DRUM LIFTER (3RD PARTY)

ESV1000 PAGE COSTS

PART #	VJCAAA
CIRCUIT BREAKER KIT #	22946-150
PACKAGE COST	\$2,100.00

(Cost does NOT include freight/installation/taxes)

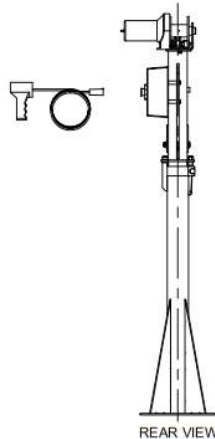
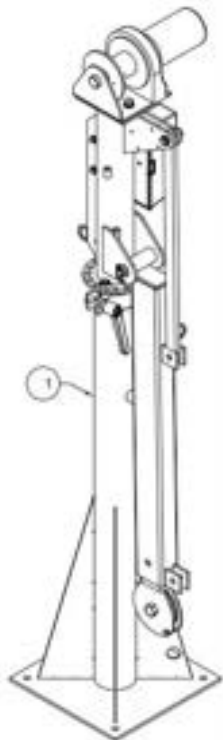

REAR VIEW

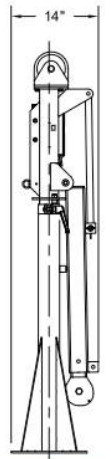

STOWED VIEW
RIGHT SIDE

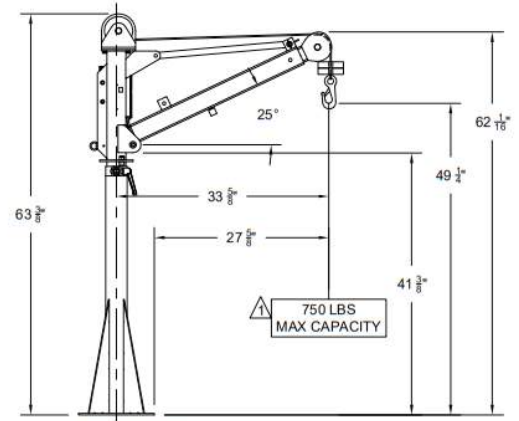

ELEVATED VIEW
RIGHT SIDE

12" TYP 10" TYP

4X Ø5/8" MOUNTING HOLES TYP
USE GRADE 5 1/2-13 HEX HEAD CAP SCREWS

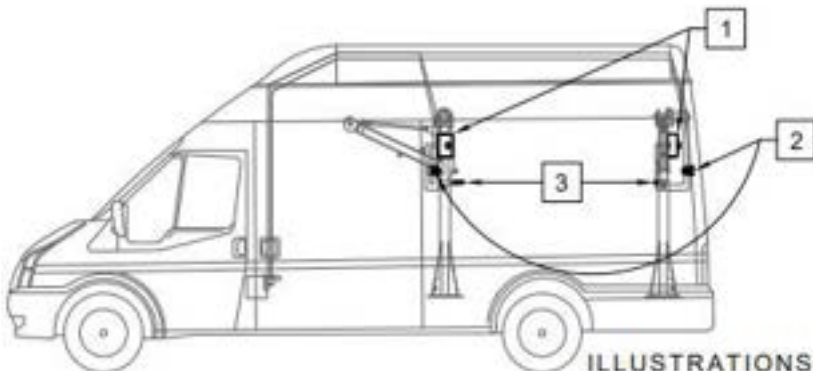

ILLUSTRATIONS FOR REFERENCE ONLY



VENTURO WARRANTY

This limited policy warrants new products of Venturo to be free from defects in material and workmanship for a period of one (1) year from date of original installation. OEM products or accessories purchased by Venturo as part of (or offered with) our product will carry the OEM manufacturer's respective warranty.

Our warranty covers:

- Repair or replacement of product
- Labor to repair or replace product
- Freight to return and/or replace product

We shall not be liable for any contingent liabilities arising out of the improper function of any products. Warranty shall become void if the product is improperly installed, modified, damaged, abused or used for application other than intended use. There is no warranty of merchantability, fitness for a particular purpose, warranty arising from course of dealing or usage of trade, or any other implied or expressed warranty, except as made specifically herein. This warranty supersedes all previous warranties, written or implied.

INSTALLATION INSTRUCTIONS

Installation and Owner's Manuals for ALL Venturo Van Cranes are available online at www.venturo.com.

Transit VC1000 Installation Manual

www.venturo.com/wp-content/uploads/INST-CEV200.pdf

Sprinter VC1000 Installation Manual

www.venturo.com/wp-content/uploads/INST-CEV310.pdf

ESV1000 Installation Manual

www.venturo.com/wp-content/uploads/INST-ESV1000.pdf

VC750FB Installation Manual

www.venturo.com/wp-content/uploads/INST-CEV181.pdf

LIABILITY STATEMENT

It is the responsibility of the installer to ensure the installation is completed according to the manufacturer's recommendations, ensure the ultimate user understands how to operate product in a safe manner, and understands the need for regular service and maintenance by an authorized Venturo Distributor. No modifications or alterations may be made to any Venturo product without the expressed written consent of Venco Venturo Industries LLC. Installation of any Venturo product must be done by an authorized Venturo Distributor, to the standards of the industry; including maintenance, service and affixing of all instruction, safety and warning decals. Users should be instructed as to the safe operation at time of delivery. Maintenance, service, operation and safety warning decals are available on request from Venco Venturo Industries LLC.



VENCO VENTURO INDUSTRIES LLC
12110 BEST PLACE
CINCINNATI, OH 45241
800-226-2238
INFO@VENTURO.COM