



LANDSCAPE & DUMP BODIES



LANDSCAPER SL BODY
MARAUDER SL DUMP BODY
MARAUDER DUMP BODY

MADE IN THE USA



What you want when there's hard work to do.

When your job demands heavy-duty hauling and dumping applications, it pays to have trucks that work in the most demanding environments. Whether you're delivering plants and gravel for a municipal project or hauling away debris from an industrial demolition site, we have the truck body that works long and hard for you.



LANDSCAPER SL BODY

It's ideal for transporting loose, bulk or skidded material that's lighter in weight but still requires room. Constructed for long-lasting durability you can count on to work hard for you job after job. Available in 9' and 12' models.



MARAUDER SL DUMP BODY

An economical body available in 2/4 yard capacity. Pack it full of lighter weight loose or bulk material to get the job done. Features an electric-hydraulic double-acting hoist with the ability to lift 8-12 tons. Choose between 9' or 11' models.



MARAUDER DUMP BODY

Our standard-duty Marauder Dump Body has all the features you need in 3/4 & 5 yard capacity. The Marauder body is engineered with a 10-gauge hot-rolled, high-strength steel interlaced understructure, dual-sidewall construction for exceptional body strength and reliability, and the performance of Class C- and D-rated hoists that can lift 8-12 tons. The Marauder Dump Body is available in 9' and 11' lengths, with the 9' having a drop-side dump option. Additional features such as tailgate latch pins and shock-mounted rear lights provide extra safety.

WE'RE HERE TO HELP.

readingtruck.com



STANDARD FEATURES LANDSCAPER SL BODY



STANDARD FEATURES LANDSCAPER SL BODY

1 CAB GUARD

10-gauge hot-rolled steel with 7-gauge sideplates. All bodies include a cab guard sized for its chassis that is permanently welded to protect the chassis and can be used to haul a properly secured wheelbarrow.

2 SUBFRAME-MOUNTED HOIST

Universal understructure is wired and ready to go to work.



3 SIDE SWING DOOR

Side door is 52" wide and swings 180°.

4 REAR BARN DOORS

Rear swing-out barn doors swing 270° for easy unloading and include a cam latch assembly.

5 REAR DOOR LATCH

The rear door latch, with holdbacks mounted on the side of the body, holds the rear door open for bed area access.

6 TENSION CLEATS

The tarp tie-down tension cleats are positioned on the sidewall so they don't interfere with the door openings.

POPULAR OPTIONS LANDSCAPER SL BODY

SLIDE AWAY ACCESS LADDER

Underbody self-storing ladder for easy tarp control or cab guard access.

FOLD AWAY ACCESS STEP

Retractable step for slide out convenience and storage. Located under the side door opening for easy curbside access.



UNDERBODY TOOLBOXES

Additional underbody toolboxes are available in aluminum or steel in sizes from 24" to 60". Can be installed on curbside or roadside.

TARP COVER

A tarp cover is available to meet your needs.

HITCH

With adjustable mounting heights, ICC underride, safety chain D-rings and choice of 2-5/16" ball/pintle combo, 2" ball/pintle combo or 2" receiver tube using Grade 8 hardware.

STANDARD FEATURES MARAUDER SL DUMP BODY

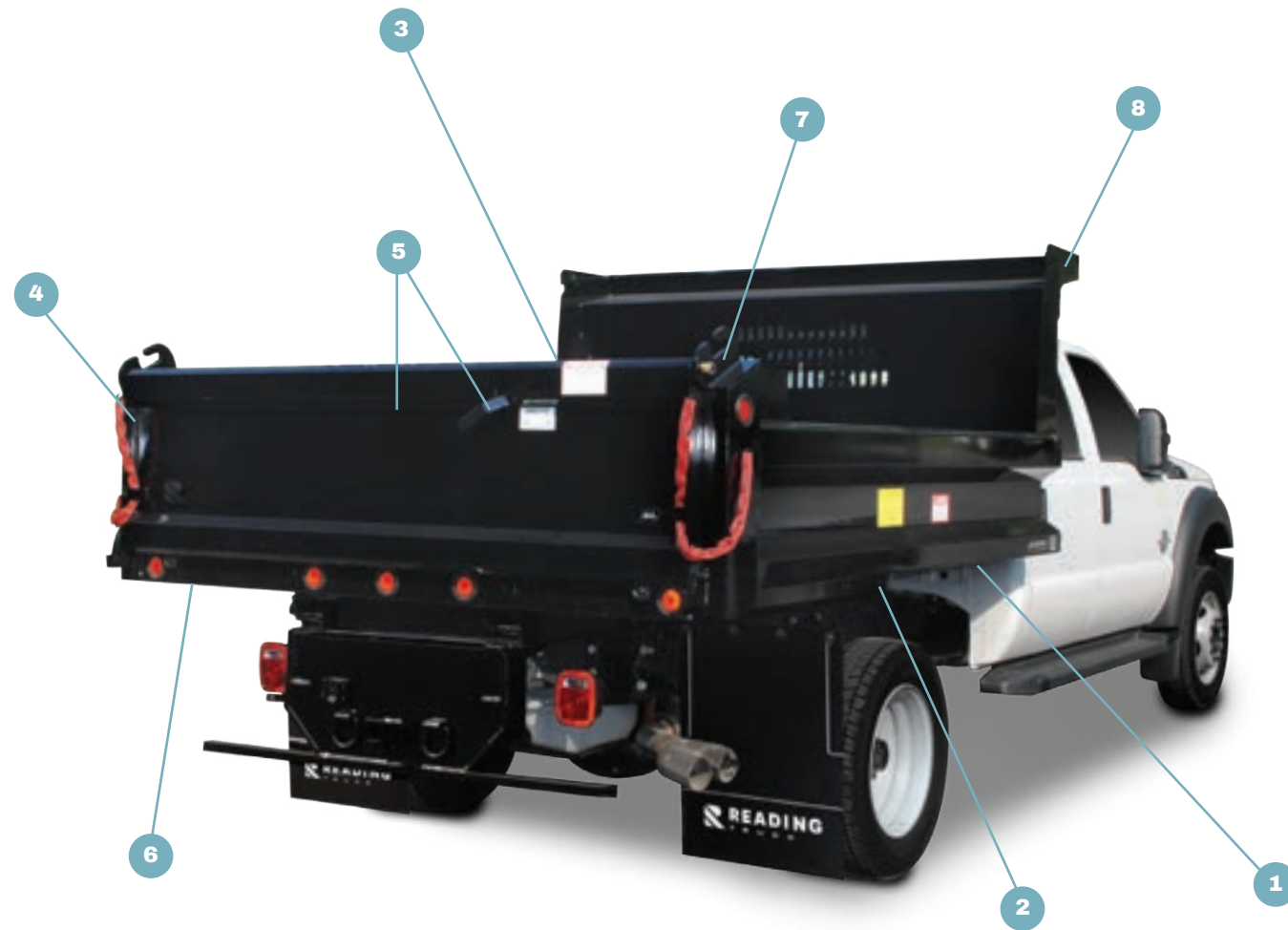

STANDARD FEATURES MARAUDER SL DUMP BODY



1 DURABLE UNDERSTRUCTURE

Durable understructure is built from 7-gauge hot-rolled steel and 3-3/4" long sills. The understructure provides lower body-mounted height for industry-leading strength and durability. Used to deliver lighter weight total package for contractors who cube out before they weigh out.

2 HYDRAULIC POWER UNIT

Double-acting (power-up/power-down) 12-volt electric-hydraulic power unit for easy operation.



3 FORWARD TAILGATE RELEASE

Release the tailgate near the front of the cab for a controlled spread of debris. The tailgate releases at the bottom and pivots at the top.

4 REAR CORNER POSTS

"Banjo eye" chain holders and tarp tension bar receivers.

5 TAILGATE

Full-width rear apron with double-acting tailgate that releases at the top and pivots at the bottom. Includes an easy open, single lever, fast-action drop-down tailgate release lever.

6 STEEL FLOOR PLATE

Two-piece HRA1011 rugged steel floor plate with angled sidewalls to floor eliminates bridging of material.

7 TAILGATE LATCH PINS

Heavy-duty tailgate latch pins and hinges with grease fittings for lubricating.

8 MODULAR BULKHEAD & CAB GUARD

The modular, full-width bulkhead and cab guard allows for convenient and cost-effective ship-thru on most chassis.

STANDARD FEATURES MARAUDER DUMP BODY



STANDARD FEATURES MARAUDER DUMP BODY



1 DURABLE UNDERSTRUCTURE

Durable understructure consists of 7-gauge formed-channel long sills and 3" structural crossmembers. Interlaced understructure provides lower body-mounted height for industry-leading strength and durability.

2 HYDRAULIC POWER UNIT

Double-acting (power-up/power-down) 12-volt electric-hydraulic power unit for easy operation.

3 FORWARD TAILGATE RELEASE

Release the tailgate near the front of the cab for a controlled spread of debris.

4 FRONT CORNER POST

Full-height front corner post provides additional structural strength to the body.

5 REAR CORNER POSTS

Full-depth rear corner posts with laser-cut hardware, "banjo eye" chain holders and tarp tension bar receivers.

6 TOP RAIL

The top rail is fully boxed for ultimate strength and angled to shed dirt and debris.

7 SHOCK-MOUNTED TAIL LAMPS

Recessed shock-mounted incandescent reverse lights installed in rear apron in addition to license plate bracket and shock-mounted, recessed LED stop and turn lights, taillights and marker lights in rear post.

8 STEEL FLOOR PLATE

Two-piece HRA1011 rugged steel floor plate with angled sidewalls to floor eliminates bridging of material.

9 EXTRA-REINFORCED TAILGATE

Full-width rear apron with double-acting tailgate and easy open, single lever, fast-action drop-down tailgate release. Made of 10-gauge steel double-wall construction with upper and lower formed box sections. Dual vertical reinforcements on a 10-gauge tailgate with formed box sections, top and bottom, provide extra stability.



10 TAILGATE LATCH PINS

Heavy-duty tailgate latch pins and hinges with grease fittings for lubricating.

POPULAR OPTIONS MARAUDER SL DUMP & MARAUDER DUMP BODIES

UNDERBODY TOOLBOXES

Additional underbody toolboxes are available in aluminum or steel in sizes from 24" to 60". Can be installed on curbside or roadside.



BACKUP ALARM

Alarm provides additional safety on the jobsite.

COAL CHUTE DOOR

To meter out your load more slowly, add a coal chute door to the rear tailgate. It opens guillotine-style to give you control of your dumping speed. (Select Marauder models only)

HITCH

1/2" steel drop plate with adjustable mounting heights, ICC underride, safety chain D-rings and choice of 2-5/16" ball/pintle combo, 2" ball/pintle combo or 2" receiver tube using Grade 8 hardware.



SIDEBOARD GUSSETS

When you need to haul larger volumes of dry material like brush, add optional bolt-on gussets that let you add larger sideboards and expand your hauling capacity.



REV-PAC

Vertical compartments provide additional storage for secure and convenient access to tools and supplies.

TARP COVER

A tarp cover is available to help secure your load.





LANDSCAPER SL BODY

LANDSCAPER SL BODY

- Landscape body with professional-quality hoist, solid sides and three solid doors, designed for conventional and/or LCF chassis cabs.

DIMENSIONAL INFORMATION

MODEL	INTERIOR LENGTH	BULKHEAD HEIGHT	CAB GUARD	SIDE DOOR OPENING	A	B	APPROX. WEIGHT
SL-LS-9 42BH/40CG	9'	42"	40"	52"	115"	155"	2,280 lbs.
SL-LS-12 42BH/40CG	12'	42"	40"	52"	151"	191"	2,625 lbs.
SL-LS-12 54BH/12CG	12'	54"	12"	52"	151"	163"	2,575 lbs.

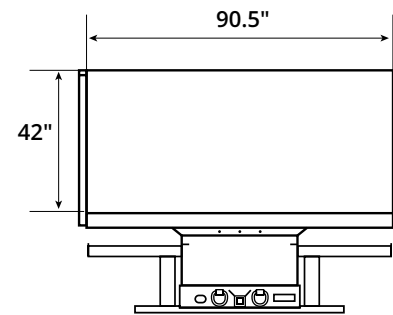
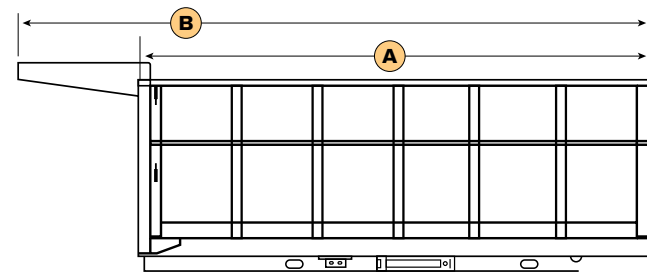

MARAUDER DUMP BODIES

MARAUDER SL DUMP BODY

- Steel dump body with electric-hydraulic double-acting hoist and single sidewall construction.
- A60 galvanized steel outer wall construction.

DIMENSIONAL INFORMATION

MODEL	DESCRIPTION	OVERALL WIDTH	OVERALL LENGTH	INSIDE WIDTH	INSIDE LENGTH	SIDEWALL HEIGHT	TAILGATE HEIGHT	BULKHEAD HEIGHT
SLMD92	9' - 2/4 Yard	95.5"	123.6"	86.6"	108"	16"	22"	52"
SLMD113	9' - 3/4 Yard	95.5"	147.6"	86.6"	132"	16"	22"	52"

Note: Coal chute and drop sides are not available on Marauder SL model.

MARAUDER DUMP BODY

- Heavy-duty steel dump body with electric-hydraulic double-acting hoist. A60 galvanized steel outer wall construction.
- Designed for Class 3-5 chassis cabs with standard 34" wide frame-rail spacing and minimum 60" cab-to-axle length.
- Powder-coated and top-coated finish in standard Gloss Black color. Also available in Prime and additional colors. Floor is hot-rolled steel.

DIMENSIONAL INFORMATION

DIMENSIONAL INFORMATION									OPTIONAL FEATURES			
MODEL	DESCRIPTION	OVERALL WIDTH	OVERALL LENGTH	INSIDE WIDTH	INSIDE LENGTH	SIDEWALL HEIGHT	TAILGATE HEIGHT	BULKHEAD HEIGHT	COAL CHUTE	DROP SIDES	COAL CHUTE & DROP SIDES	BULKHEAD
MD92	9' - 2/3 Yard	96"	133"	87.375"	108"	16"	22"	52"	•	•	•	
MD113	11' - 3/4 Yard	96"	157"	87.375"	132"	16"	22"	52"	•			
MD95	9' - 4/5 Yard	96"	133"	87.375"	108"	20"	26"	52"				61.5"



READING TRUCK WARRANTY

WARRANTIES AS STRONG AS OUR BODIES.

We back our work truck bodies and installations with some of the strongest, longest warranties in the business. Product registration is fast and easy on our website, readingtruck.com.

LANDSCAPER SL BODY



MARAUDER SL DUMP BODY



MARAUDER DUMP BODY



INSTALLATION



NO ONE KNOWS WORK TRUCKS BETTER THAN US.

We are a leading manufacturer and distributor who has been designing and building work truck bodies with outstanding craftsmanship for more than 65 years. You can depend on us for safe, durable truck bodies; expert installation; and all the parts, equipment, accessories and services you need to get the job done.

Our products are available through our extensive national network of distribution partners, or through any of our 20 Reading Truck equipment locations, where you'll find everything you need to outfit a single truck or an entire fleet.

Our success comes from putting you first; understanding what you need to work at your very best and being there for you.



825 E. Wyomissing Blvd.
Reading, PA 19611

readingtruck.com

Sold and Serviced Locally by



**© 2023 Reading Truck Group. All rights reserved.
Version Number L103-B (3/2023)**

All dimensions subject to plus or minus tolerance of $\frac{1}{4}$ " and all dimensions and specifications are subject to change without notice. Some items displayed in photographs are optional. Aluma-Fill, Dual-Pro, Extend-A-Shelf, Latch-Matic, Reading Truck, Redi-Dek, and Spacemaker are registered trademarks of The Reading Truck Group, LLC, (DBA Reading Truck) in the United States and some foreign countries. Trademarks of other firms are property of their respective owners.